



C2M.v2.7.CCB

3.3.1.1 Establish Person and or Accounts

Creation Date: February 28, 2009

Last Updated: February 11, 2020

ORACLE®

Copyright © 2019, Oracle. All rights reserved.

This document is provided for information purposes only and the contents hereof are subject to change without notice.

This document is not warranted to be error-free, nor subject to any other warranties or conditions, whether expressed orally or implied in law, including implied warranties and conditions of merchantability or fitness for a particular purpose. We specifically disclaim any liability with respect to this document and no contractual obligations are formed either directly or indirectly by this document. This document may not be reproduced or transmitted in any form or by any means, electronic or mechanical, for any purpose, without our prior written permission. Oracle, JD Edwards, PeopleSoft, and Siebel are registered trademarks of Oracle Corporation and/or its affiliates. Other names may be trademarks of their respective owners.

Contents

BRIEF DESCRIPTION	4
BUSINESS PROCESS MODEL PAGE 1	5
BUSINESS PROCESS MODEL PAGE 2	6
DETAIL BUSINESS PROCESS MODEL DESCRIPTION.....	7
TEST DOCUMENTATION RELATED TO THE CURRENT PROCESS	21
DOCUMENT CONTROL	22
ATTACHMENTS	23
<i>Person Page:</i>	23
<i>Customer Contact Page:</i>	23
<i>Account Page:</i>	23
<i>Account/Person Page:</i>	23

Brief Description

Business Process: 3.3.1.1 C2M.CCB.Establish Person and or Account
Process Type: Sub-Process
Parent Process: 3.3.1 C2M.CCB.Gather and Maintain Customer Information
Sibling Processes:

This business process depicts scenarios when customers calls in to add or remove person(s) from account, to create a new person or an account, modify a person(s) demographic information or account information. This process describes how person(s) and or account records are created, maintained and removed. An authorized users evaluates every request and make necessary changes using C2M user interface. C2M Master Configuration makes sure that information is synced in between CCB and MDM seamlessly. All the sub-processes and necessary configuration are discussed in detailed in this document.

Business Process Model Page 1

3.3.1.1 C2M.V2.7.CCB *Establish Person and or Account*

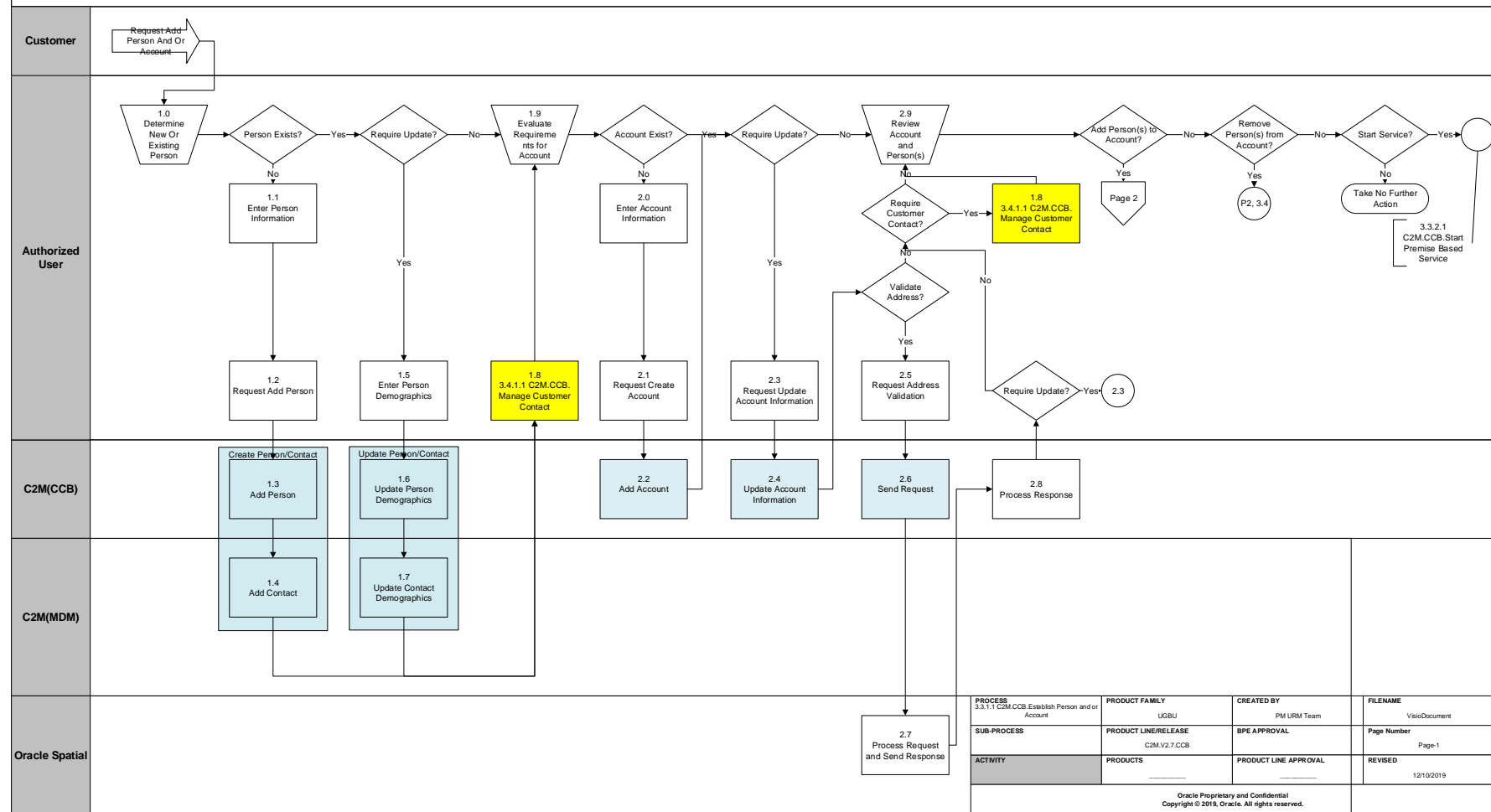

Business Process Model Page 2

3.3.1.1 C2M.V2.7.CCB *Establish Person and or Account*

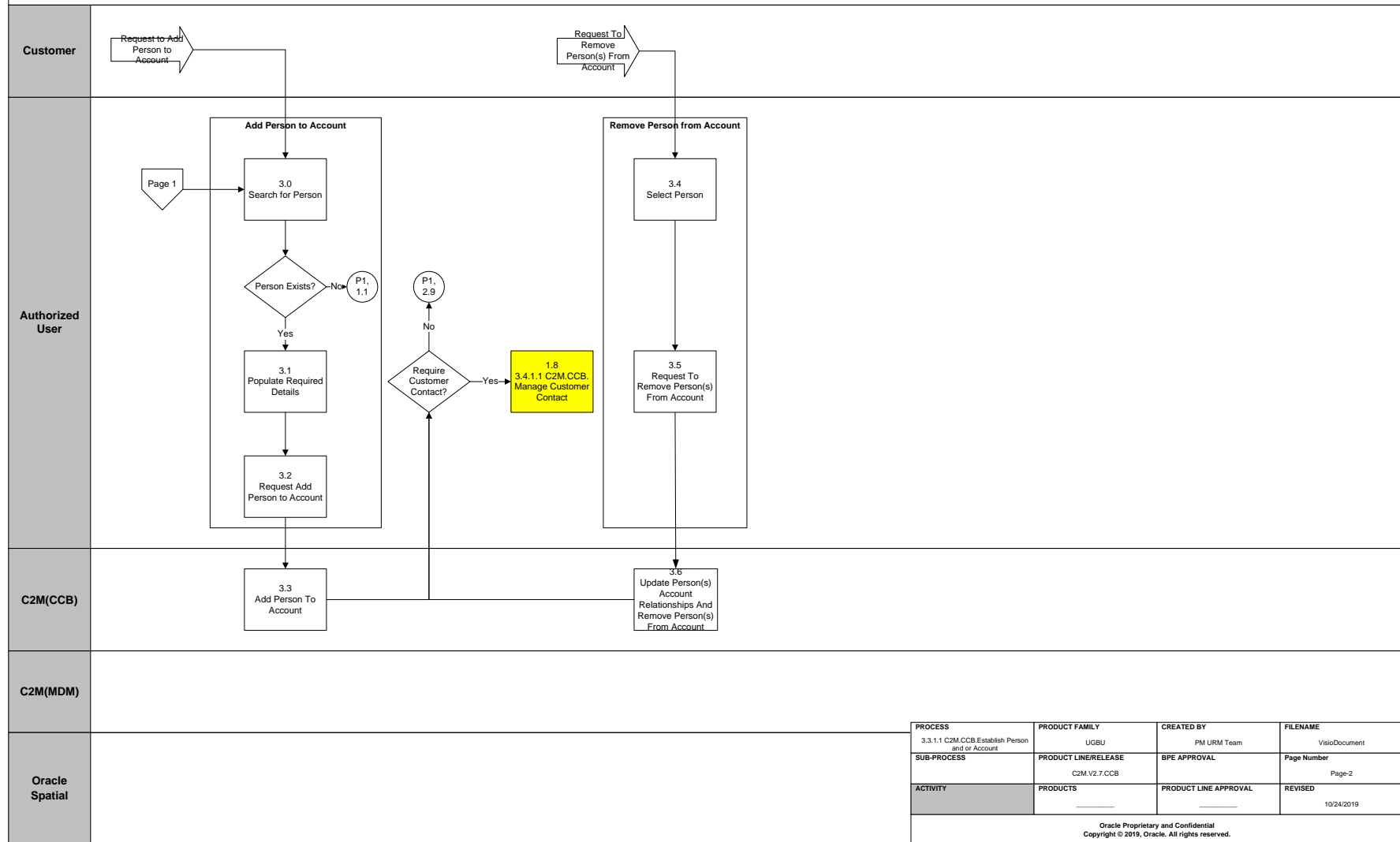

PROCESS	PRODUCT FAMILY	CREATED BY	FILENAME
3.3.1.1 C2M.CCB.Establish Person and or Account	UGBU	PM URM Team	VisioDocument
SUB-PROCESS	PRODUCT LINE/RELEASE	BPE APPROVAL	Page Number
	C2M.V2.7.CCB		Page-2
ACTIVITY	PRODUCTS	PRODUCT LINE APPROVAL	REVISED
			10/24/2019
Oracle Proprietary and Confidential Copyright © 2019, Oracle. All rights reserved.			

Detail Business Process Model Description

1.0 Determine New or Existing person

Actor/Role: Authorized User

Description:

At first Authorized User determines whether a person exist or need to create a new person using a Control Central Search on Control Central page. Authorized User is responsible for fulfilling customer requests.

1.1 Enter Person Information

Actor/Role: Authorized User

Description:

If customer does not exist, enter person demographic information on [Person Page](#). Authorized User will need to know if this is a person or business, whether person has life support or sensitive load equipment, person names, person phone numbers and person ids.

1.2 Request Add Person

Actor/Role: Authorized User

Description:

If needed to add a person, the Authorized User requests it from the [Person Page](#).

1.3 Add Person

Actor/Role: C2M(CCB)

Description:

The Person is added in C2M(CCB) [Person Page](#). C2M uses Internal Synchronization process to update Contact information in C2M(MDM).

Process Plug-in enabled: Y **Available Algorithm(s):**

PERS-INFO (Main name (alternate name) - phone number)
C2MPERS-INFO (Main name (alternate name) - phone number)
NMFM-VALFMT (Person Name Format Validation (Last,First))
C2M-PERNMVAL (Person Name Format Validation (Last,First))
C1-VALPHFMT (Validate Phone Format)
PHN-FMT (Validate Phone Number)
ADVH-PHN (Validates Phone Number Format)
C1-CMDM2PRF(Capture MDM2 Person-Based Final Snapshot)
X1-CMDM2PRI (Capture Person-Based Initial Snapshot)

C1-FMTPERNAM (Format Person Name)
C1-LSSL-PER (Highlight Person Life Support/Sensitive Load)
C1_LSSL-DF (Highlight Life Support/Sensitive Load on Person)
C1-PCT-INFO (Person Contact Info Formatter)
C2M-PERCTINF(Person Contact Info Formatter)
C1-PERCTYPVL (Person Contact Type Validation)
C1-SRRFAPP(Social Issue Resolution Request - Find Account / Person / Premise)
X1-SENDPESY (Synchronizes CCB Person to MDM Contact)
CIPERID-EIN (Validate if person ID is in a valid format)
C2M-ID-EIN (Validate ID is in NN-NNNNNN format)
CIPERID-SSN (Validate if person ID is in a valid format)
C2M-ID-SSN (Validate ID is in NNN-NN-NNNN format)
C1-VALFIN (Validate person ID format and control character)
C1-VALNIN (Validate person ID format and control character)
C1-IDFM-PIDF (Validate person ID format and verification digit)

Configuration required: Y Entities to Configure:

Installation Options-Person
Installation Options-Framework - Person Information
Installation Options-Framework - Person Name Validation
Master Configuration - Customer to Meter Configuration
Extendable Lookup - CCB Contact Type Mapping
Extendable Lookup - Contact Type
Contact Type
Customer Contact Class

Person Relation Type
Phone Type
Identifier Type
Feature Configuration - C2M-CUSTINFO

Business Objects: Y

Business Objects:

X1-MDM2Person (C2M MDM Person)
C1-InstallationPerson (Installation Options - Person)
C1-MDM2Person (MDM2 Person)
C1-MDM2PersonContact (MDM2 Person Contact)
CI_MDM2Business (MDM2 Business)
D1-Person (Person)
WX-Person (Person)
C1-PersonContactDetails(Person - Get Contact Details)
C1-PersonContact (Person Contact BO)
C1-PersonContactData (Person Contact Data)
C1-PersonContactType (Person Contact Type)
C1-PersonContactTypeLite (Person Contact Type Lite)
C1-MDM1Person (Person Information for MDM1 SA Sync)
C1-PersonLite (Person Lite)
C1-PersonNameContact (Person Name Contact)
D1-Business (Business)
C1PersonPhysical (Physical BO for Person)
C1-PerContactTypePhysicalBO (Physical BO for Person Contact Type)
C1-PersonRelTypePhysicalBO (Physical BO for Person Relationship Type)
X1-C2MMasterConfiguration (Customer to Meter Configuration)

Process Scripts: Y

Script:

C1-FmtPerNam (Format Person Name)
WX-PerInfo (Person Information)
WX-PerList (Person List)
WX-PhoneUpd (Update Person Contact Info)
C1-CustMtReq (Customer Maintenance Request)
C1-AddPerCnt (Add Person Contact)

Customizable Scripts: Y**Script:**

C1-INPUS (Create Person Contact from Person Phone/Email)
D2-CONIL (Contact Initial Load)

1.4 Add Contact**Actor/Role: C2M(MDM)****Description:**

C2M uses Internal Synchronization process to update Contact information in C2M(MDM). The Internal Synchronization process is performed in a single transaction. A Pre-processing Algorithm uses Extendable Lookups to translate between Oracle Utilities CCB codes and Oracle Utilities MDM codes.

1.5 Enter Person Demographics**Actor/Role: Authorized User****Description:**

If person demographic data requires updating, the Authorized User navigates to [Person Page](#) to update demographic data.

1.6 Update Person Demographics**Actor/Role: C2M(CCB)****Description:**

Person Demographics are updated into the C2M(CCB) using the Person Page.

Process Plug-in enabled: Y**Available Algorithm(s):**

PERS-INFO (Main name (alternate name) - phone number)
C2MPERS-INFO (Main name (alternate name) - phone number)
NMFM-VALFMT (Person Name Format Validation (Last,First))
C2M-PERNMVAL (Person Name Format Validation (Last,First))
C1-VALPHFMT (Validate Phone Format)
PHN-FMT (Validate Phone Number)
ADVH-PHN (Validates Phone Number Format)
C1-CMDM2PRF(Capture MDM2 Person-Based Final Snapshot)
X1-CMDM2PRI (Capture Person-Based Initial Snapshot)

C1-FMTPERNAM (Format Person Name)
C1-LSSL-PER (Highlight Person Life Support/Sensitive Load)
C1_LSSL-DF (Highlight Life Support/Sensitive Load on Person)
C1-PCT-INFO (Person Contact Info Formatter)
C2M-PERCTINF(Person Contact Info Formatter)
C1-PERCTYPVL (Person Contact Type Validation)
C1-SRRFAPP(Social Issue Resolution Request - Find Account / Person / Premise)
X1-SENDPESY (Synchronizes CCB Person to MDM Contact)
CIPERID-EIN (Validate if person ID is in a valid format)
C2M-ID-EIN (Validate ID is in NN-NNNNNN format)
CIPERID-SSN (Validate if person ID is in a valid format)
C2M-ID-SSN (Validate ID is in NNN-NN-NNNN format)
C1-VALFIN (Validate person ID format and control character)
C1-VALNIN (Validate person ID format and control character)
C1-IDFM-PIDF (Validate person ID format and verification digit)

Configuration required: Y Entities to Configure:

Installation Options-Person
Installation Options-Framework - Person Information
Installation Options-Framework - Person Name Validation
Master Configuration - Customer to Meter Configuration
Extendable Lookup - CCB Contact Type Mapping
Extendable Lookup - Contact Type

Contact Type
Customer Contact Class
Person Relation Type
Phone Type
Identifier Type
Feature Configuration - C2M-CUSTINFO

Business Objects: Y**Business Objects:**

X1-MDM2Person (C2M MDM Person)
C1-InstallationPerson (Installation Options - Person)
C1-MDM2Person (MDM2 Person)
C1-MDM2PersonContact (MDM2 Person Contact)
CI_MDM2Business (MDM2 Business)
D1-Person (Person)
WX-Person (Person)
C1-PersonContactDetails(Person - Get Contact Details)
C1-PersonContact (Person Contact BO)
C1-PersonContactData (Person Contact Data)
C1-PersonContactType (Person Contact Type)
C1-PersonContactTypeLite (Person Contact Type Lite)
C1-MDM1Person (Person Information for MDM1 SA Sync)
C1-PersonLite (Person Lite)
C1-PersonNameContact (Person Name Contact)
D1-Business (Business)
C1PersonPhysical (Physical BO for Person)
C1-PerContactTypePhysicalBO (Physical BO for Person Contact Type)
C1-PersonRelTypePhysicalBO (Physical BO for Person Relationship Type)
X1-C2MMasterConfiguration (Customer to Meter Configuration)

Process Scripts: Y**Script:**

C1-FmtPerNam (Format Person Name)
WX-PerInfo (Person Information)
WX-PerList (Person List)
WX-PhoneUpd (Update Person Contact Info)
C1-CustMtReq (Customer Maintenance Request)
C1-AddPerCnt (Add Person Contact)

Customizable Scripts: Y**Script:**

C1-INPUS (Create Person Contact from Person Phone/Email)
VAL-PER (Validate person)
D2-CONIL (Contact Initial Load)

1.7 Update Contact Demographics**Actor/Role:** C2M(MDM)**Description:**

C2M uses Internal Synchronization process to update Contact Demographics in C2M(MDM). The Internal Synchronization process is performed in a single transaction. A Pre-processing Algorithm uses Extendable Lookups to translate between Oracle Utilities CCB codes and Oracle Utilities MDM codes.

1.8 3.4.1.1 C2M.CCB.Manage Customer Contact**Actor/Role:** Authorized User**Description:**

Authorized User enters customer contact information to keep records on [Customer Contact Page](#). Refer to process 3.4.1.1 Manage Customer Contacts.

1.9 Evaluate Requirements for Account**Actor/Role:** Authorized User**Description:**

Before proceeding with a customer request, Authorized User performs due diligence on an Account. For example, it make sure the Account does not has any previous balance, credit history, or any existing alerts. User may also get a quick view of Account on Control Central using the Account Information option from the Menu Bar.

2.0 Enter Account Information**Actor/Role:** Authorized User**Description:**

If account exists, but requires update then Authorized User enters account information on the [Account Page](#). Entered Account information could be displayed differently based on Authorized User needs (main Account info could be configured for display to contain different info)

2.1 Request Create Account**Actor/Role:** Authorized User**Description:**If an account doesn't exist, the Authorized User requests it from the [Account Page](#).**2.2 Add Account****Actor/Role:** C2M(CCB)**Description:**Authorized User creates Account using [Account Page](#). Also an Account can be created automatically and linked to the Person when Person is created or updated using [Person Page](#). Account is added and stored in C2M(CCB). Once the Account is created in C2M(CCB), it remains there and never expires.**Process Plug-in enabled:** Y**Available Algorithm(s):**

C1-AC-INFO (Account Information)
C1-ACCT-INFO (Account Information)
C1-LDACCTINF (Account Lead Customer Information)
C1-CASH-ACCT (Highlight Cash Only Account)
C1_CASH-DF (Cash Only Account)
CRPS-PE (Create/Link Additional Person for Account)
C1-SRRFAPP (Social Issue Resolution Request - Find Account / Person / Premise)
C1-MPOAC-AGP (Use Access Group of Main Person's Other Account)
WX-VACCOUNT (Verify Account)
C1-NT-VALCC(Validate Contact Class and Contact Type)
C1-APOL-RA (Create a To Do entry if autopay over account's limit)
C1-ICGETCC (Retrieve customer class)
F1-SYNRQALRT (Retrieve Outstanding Sync Request)

Configuration required: Y**Entities to Configure:**

Installation Options - Account
Installation Options-Framework - Account Information
Installation Options-Framework - Control Central Alert
Access Group
Account Management Group
Account Relationship type
Auto Pay Source Type
Bill Cycle
Bill Message
Collection Class
Collection Class Control
Communication Type
Customer Contact Class
Currency
Person Relationship Type
User

Business Objects: Y**Business Objects:**

WX-Account (Account)
C1-AccountManagementAccount (Account - Account Management)
C1-AccountPerson (Account - Account/Person)
C1-AccountMainPerson (Account - Get Main Person ID)
C1-AccountBillMessage (Account Bill Message)
C1-AccountCurrency (Account - Get Currency Code)
C1-AccountCreditReviewSchedule (Account Credit Review Schedule)
C1-MDM1Account (Account Information for MDM1 SA Sync)
C1-MDM2Account (MDM2 Account)
CI_AccountCustomerInfo (Account fields common to all account BOs)
CI_StopAutopayAccount (Stop Auto Pay Account)
WX-RetAcctRelType (Retrieve Account Relationship Type Description)

Process Scripts: Y**Script:**

WX-AcctInfo (Account Information)
C1-AMUpdAcct (Account Management - Update Account)
C1-ValAccPer (Validate Account and/or Person)
C1-ShwZnInAc(Zone Visibility - Restricted Accounts)

Customizable Scripts: Y**Script:**

C1-ADM (Account Debt Monitor)

2.3 Request Update Account Information**Actor/Role:** Authorized User**Description:**If an Account information requires an update then Authorized User updates information Account using [Account Page](#).**2.4 Update Account Information****Actor/Role:** C2M(CCB)**Description:**Account information is updated on [Account Page](#).**Process Plug-in enabled: Y****Available Algorithm(s):**

CL_ACCT-INFO (Account information)
C1-ACCT-INFO (Account Information)
C1-CASH-ACCT (Highlight Cash Only Account)
C1_CASH-DF (Cash Only Account)
CRPS-PE (Create/Link Additional Person for Account)
C1-SRRFAPP (Social Issue Resolution Request - Find Account / Person / Premise)
C1-MPOAC-AGP (Use Access Group of Main Person's Other Account)
WX-VACCOUNT (Verify Account)
C1-NT-VALCC(Validate Contact Class and Contact Type)
C1-APOL-RA (Create a To Do entry if autopay over account's limit)
F1-SYNRQALRT (Retrieve Outstanding Sync Request)
C1-ICGETCC (Retrieve customer class)
C1-CRRT-BA (Retrieve account's bill after date)

Configuration required: Y Entities to Configure:

Installation Options - Account
Installation Options-Framework - Account Information
Installation Options-Framework - Control Central Alert
Access Group
Account Management Group
Account Relationship type
Auto Pay Source Type
Bill Cycle
Bill Message
Collection Class
Collection Class Control
Communication Type
Customer Contact Class
Currency
Person Relationship Type
User

Business Objects: Y

Business Objects:

WX-Account (Account)
C1-AccountManagementAccount (Account - Account Management)
C1-AccountPerson (Account - Account/Person)
C1-AccountMainPerson (Account - Get Main Person ID)
C1-AccountBillMessage (Account Bill Message)
C1-AccountCurrency (Account - Get Currency Code)
C1-AccountCreditReviewSchedule (Account Credit Review Schedule)
C1-MDM1Account (Account Information for MDM1 SA Sync)
C1-MDM2Account (MDM2 Account)
CI_AccountCustomerInfo (Account fields common to all account BOs)
CI_StopAutopayAccount (Stop Auto Pay Account)
WX-RetAcctRelType (Retrieve Account Relationship Type Description)
D2-BillCycle (Bill Cycle)

Process Scripts: Y**Script:**

WX-AcctInfo (Account Information)
C1-AMUpdAcct (Account Management - Update Account)
C1-ValAccPer (Validate Account and/or Person)
C1-ShwZnInAc(Zone Visibility - Restricted Accounts)

Customizable: Y**Script:**

C1-ADM (Account Debt Monitor)

2.5 Request Address Validation**Actor/Role:** Authorized User**Description:**

If address requires validation, Authorized User requests it from the [Account/Person Page](#) , in case of Account Address Override. It can also be used from Person Correspondence Page.

2.6 Send Request**Actor/Role:** C2M(CCB)**Description:**

C2M(CCB) initiates a request to Oracle Spatial to verify the address. As the response is sent immediately upon request, C2M uses an online spatial validation, if available.

Process Plug-in enabled: Y**Available Algorithm(s):**

F1-ORAGEOCD - Oracle Spatial Geocoding.
C1-ICGEOVVAL (Geographic Value Criteria Validation)

Process Scripts: Y**Script:**

C1-ValAddr (Address Validation Using Geocoding)
C1-GetGeoLL (Retrieve Latitude/Longitude Geographic Value)

Configuration required: Y Entities to Configure:

Installation Options - Framework - Geocoding Service
Feature Configuration - C2M-GENSYSTEM (General System Configuration)

2.7 Process Request and Send Response

Actor/Role: Oracle Spatial

Description:

Oracle Spatial receives and processes the request. The return code will identify the match quality (where 1 is perfect match). As the response is sent immediately upon request, C2M uses an online spatial validation, if available.

2.8 Process Response

Actor/Role: C2M(CCB)

Description:

C2M(CCB) shows a message accordingly to the return code as premise address validated.

2.9 Review Account and Person(s)

Actor/Role: Authorized User

Description:

Authorized User makes sure that all the information regarding the Account, Person(s), address and demographics are valid and have not raised any flags. Authorized User reviews Account and Person information using [Account/Person Page](#).

3.0 Search for Person

Actor/Role: Authorized User

Description:

When a customer requests to add a person on an account, at first Authorized User searches for person using [Person Page](#). If person doesn't exist, Authorized User creates the person.

3.1 Populate Required Details

Actor/Role: Authorized User

Description:

Authorized User updates all the required information of a new person to be added on the account using the [Person Page](#).

3.2 Request Add Person to Account

Actor/Role: Authorized User

Description:

Authorized User makes sure that the person(s) in C2M(CCB) is associated to the customer before requesting to their account. Authorized User needs to fill in the additional requirement like financial responsibility, receiving of bill copy, Collection information, Communication preferences and address information, if required.

3.3 Add Person To Account

Actor/Role: C2M(CCB)

Description:

An Authorized user adds person(s) to C2M(CCB) using [Account/Person Page](#).

3.4 Select Person

Actor/Role: Authorized User

Description:

Authorized User selects the person(s) associated with a customer, to be removed from C2M(CCB).

3.5 Request to Remove Person(s) From Account

Actor/Role: Authorized User

Description:

Authorized User makes sure that the person(s) to remove is associated to the customer and then requests to remove.

3.6 Update Person(s) Account Relationships And Remove Person(s) From Account

Actor/Role: C2M(CCB)

Description

Based on customer request Authorized User updates the Person Account relationships and removes person(s) from an account using [Account/Person Page](#). Authorized User needs to make sure that during the removal, one person should have Main Customer as relationship. Relationships between Person and Account are stopped, however person relationship link can be viewed through Person page.

Test Documentation related to the Current Process

ID	Document Name	Test Type

Document Control

Change Record

Date	Author	Version	Change Reference
2/26/2009	Stephanie Rogers	Draft 1a	No Previous Document
3/19/2009	Galina Polonsky		Reviewed
9/24/2010	Geir Hedman		Updated with new Visio
9/28/2010	Yoko Iwahiro		Update configuration, algorithms, and business objects.
2/8/2011	Geir Hedman		Update document and Visio
1/29/2013	Pablo Siegrist		Update document and Visio with v2.4 enhancements
09/15/2013	Galina Polonsky		Reviewed, Approved
09/02/15	Muhssin Suliman		Update for CCBv2.5
11/15/2013	Galina Polonsky		Reviewed, Approved
10/23/2017	Kashif Qureshi		Redesign process for C2M
10/26/2017	Chetan Raut		Updated for C2M
10/29/2017	Galina Polonsky		Reviewed, Approved
05/29/2019	Satya Kalavala		Updated format for v2.7

Attachments

Person Page:



"Person Page.doc"

Customer Contact Page:



"Customer Contact
Page.doc"

Account Page:



"Account Page.doc"

Account/Person Page:



Account_Person
Page.doc